



**YOUR
RETAIL
JOURNEY
STARTS
HERE**

power, **trust**, glory



ÜÇGE, with its 48 years of experience and innovative vision, is one of the largest suppliers of the retail and logistics industry in the world.

With its special products for its innovative product range, it produces store equipment and warehouse shelving systems for boutique stores, hypermarket, electronic shops, DIY-Stores, cosmetic-drugstores, glassware and many other sales points of the industry.

As a company, exporting to 92 countries, ÜÇGE provides service with its sales team and warehouse organization together with its company WORLD Shopfitting & Design in Köln, Germany, the center

of Europe, in order to reach the retail and logistics industry more easily on the international platform.

ÜÇGE is also launching its new generation smart products focused on innovation and technology, developed in its R&D Center and appealing to retail, logistics, industry and all sectors, under its new brand blu.xone.

ÜÇGE providing service and operating with its 10 companies in 6 different plants and 750 employees established in Bursa, its office in Germany and more than 40 distributors worldwide; continue to move forward with the goal of leadership at the international level.



high-standard technology plant

ÜÇGE manufactures shelving systems, together with the technology investments it takes into the plan, based on efficiency that show resistance according to the needs.

In addition to wide varieties of shelving and shopfitting equipment produced by ÜÇGE, the company also offers the most suitable conceptual solutions for the expectations and needs of the retail industry through the new generation wire rack system registered under the name of Saturn Concept developed and manufactured under the robotic manufacturing-line system.

ÜÇGE became the first and only R&D Center in the sector in Turkey and has shown innovative power and systematic development in world standards by continuously implementing the firsts in its sector.



natural materials processed for manufacturing

Different materials, like wood, steel and plexiglass are processed in finesse to manufacture customized fixtures and create concepts which our clients require.

▶ METAL PROCESSING



▶ WIRE PROCESSING

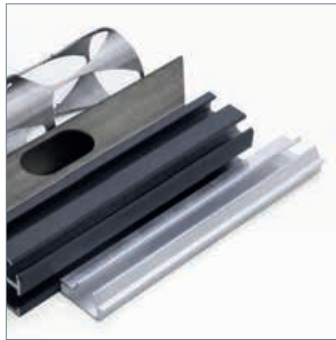

▼ PROFILE PROCESSING



▼ WOOD PROCESSING

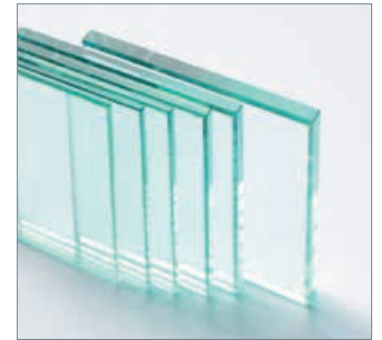

▼ GLASS PROCESSING

supermarket & hypermarket

We provide solutions that make stores practical and aesthetically pleasing, satisfying customers' preferences and needs with a production capacity capable of fulfilling any design and request.





















beverage

We attach importance to design for the regular and elegant display of products in beverage aisles, offer functional solutions, and bring high technology into the design for unique beverage merchandising aisles.



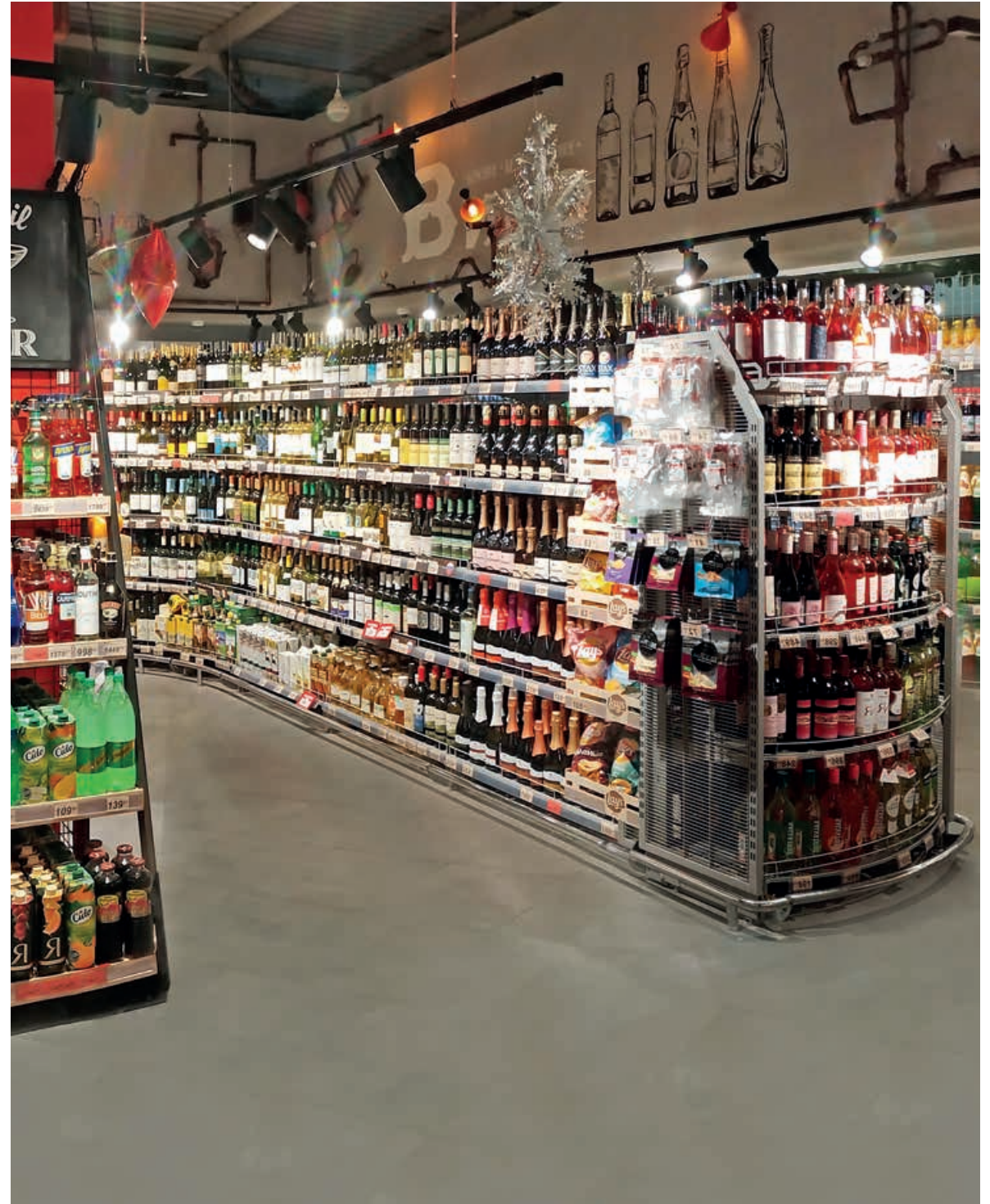

bakery

Bakery product aisles and display units are meticulously manufactured to provide the display for a wide variety of fast-consuming bakery products hygienically and the proper stance to maintain their freshness for a long time.



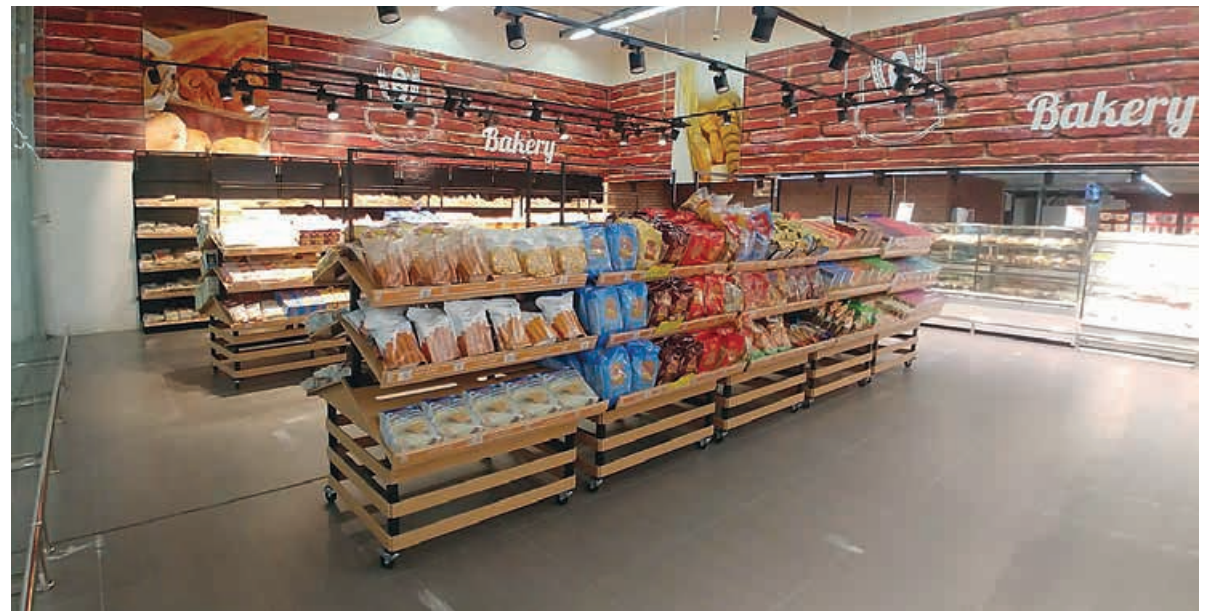



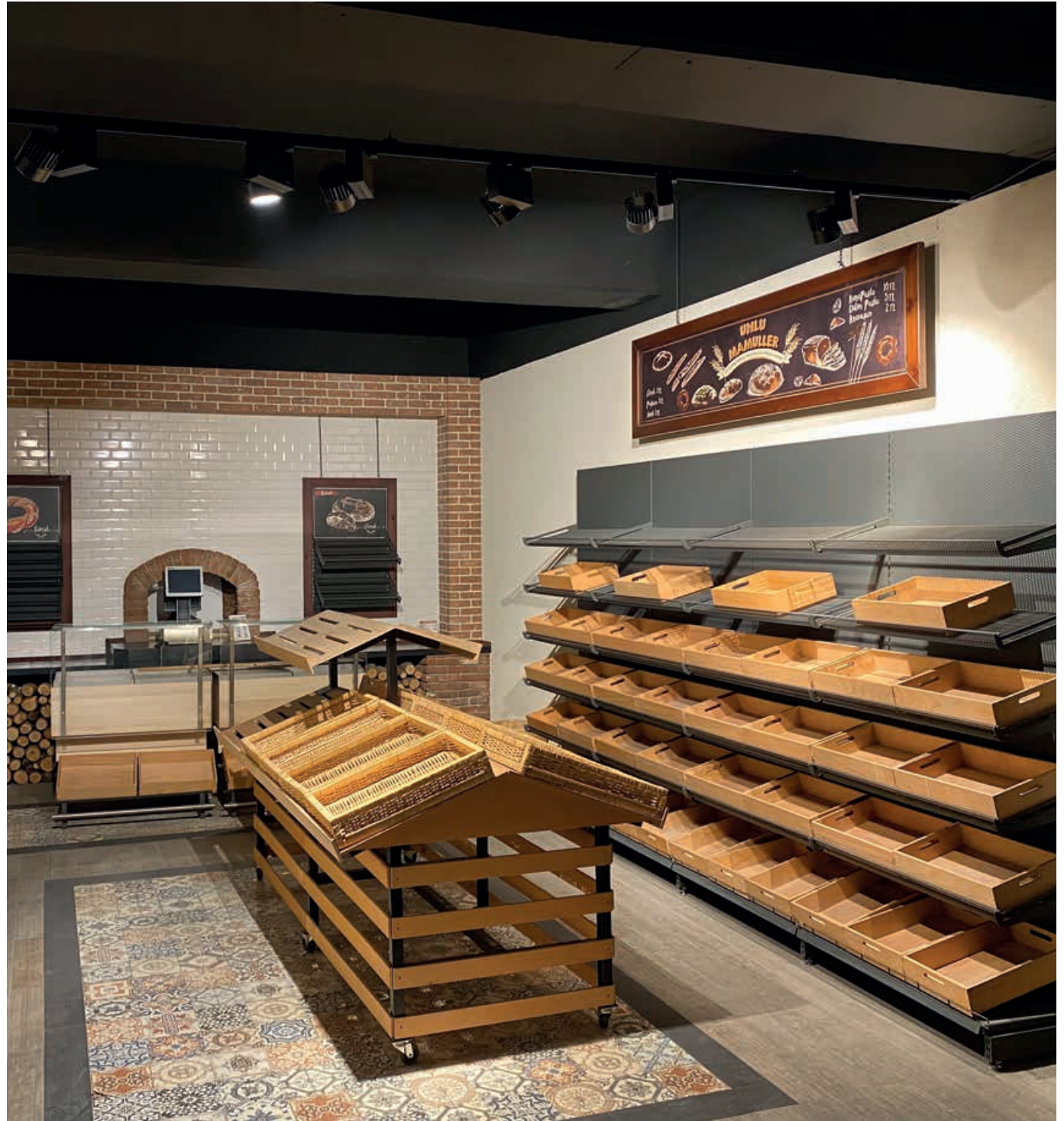

fruits & vegetables

At the fruit and vegetable aisles, the proper positioning of fresh food goods product groups and the attention to environmental hygiene significantly impact the store atmosphere, while the fresh food display units manufactured by ÜÇGE increase your brand value and the intention of purchasing while creating the vision of product availability.









check-outs

Check-out counters are the essential aspect of point-of-sales and the ultimate contact point for customers. A unique approach to making shopping easier and checking out faster while aiming to match the store concept with stylish designs is a purpose of ÜÇGE's vision.

As a result, a must-have sustainable ÜÇGE branded check-out counter solution provides an ergonomic adaptation of the POS hardware and the efficient sales-boosting shelf spaces that enable the cross-sales strategies.









Müşterilerimizle
iletişimde dürüst,
açık sözlü ve
açık görüşlü
olmayı amaçlarız.
METRO
Güvenilirsiniz

METRO
10 taksit

14

13

Sürekli olarak
müşteri ihtiyaç ve
memnuniyeti
odaklı çalışırız.
METRO
Güvenilirsiniz

Müşterilerimizin
özellikli parçaları
kaybolmasını
facadeyi almama
teslimatı için.
METRO
Güvenilirsiniz

12

8

BAYIR ÇIKIŞ

KAPALI

boutique

For boutique stores, we carefully approach the details under the disciplinary foundations of fashion retail shop fittings to fit into the desired concepts of global brands.

As ÜÇGE's conceptual display units for boutique retail can be combined with various wooden coating, stainless steel, wire, plexiglass, glass, or lacquered painting, the store atmosphere and the product availability aspects are boosted to meet the demands of the shopper in any boutique retail store.













sports apparel

The energetic and sporty atmosphere we build in sportswear and apparel stores contributes significantly to the shopping experience and creates the correct brand perception for your customers.





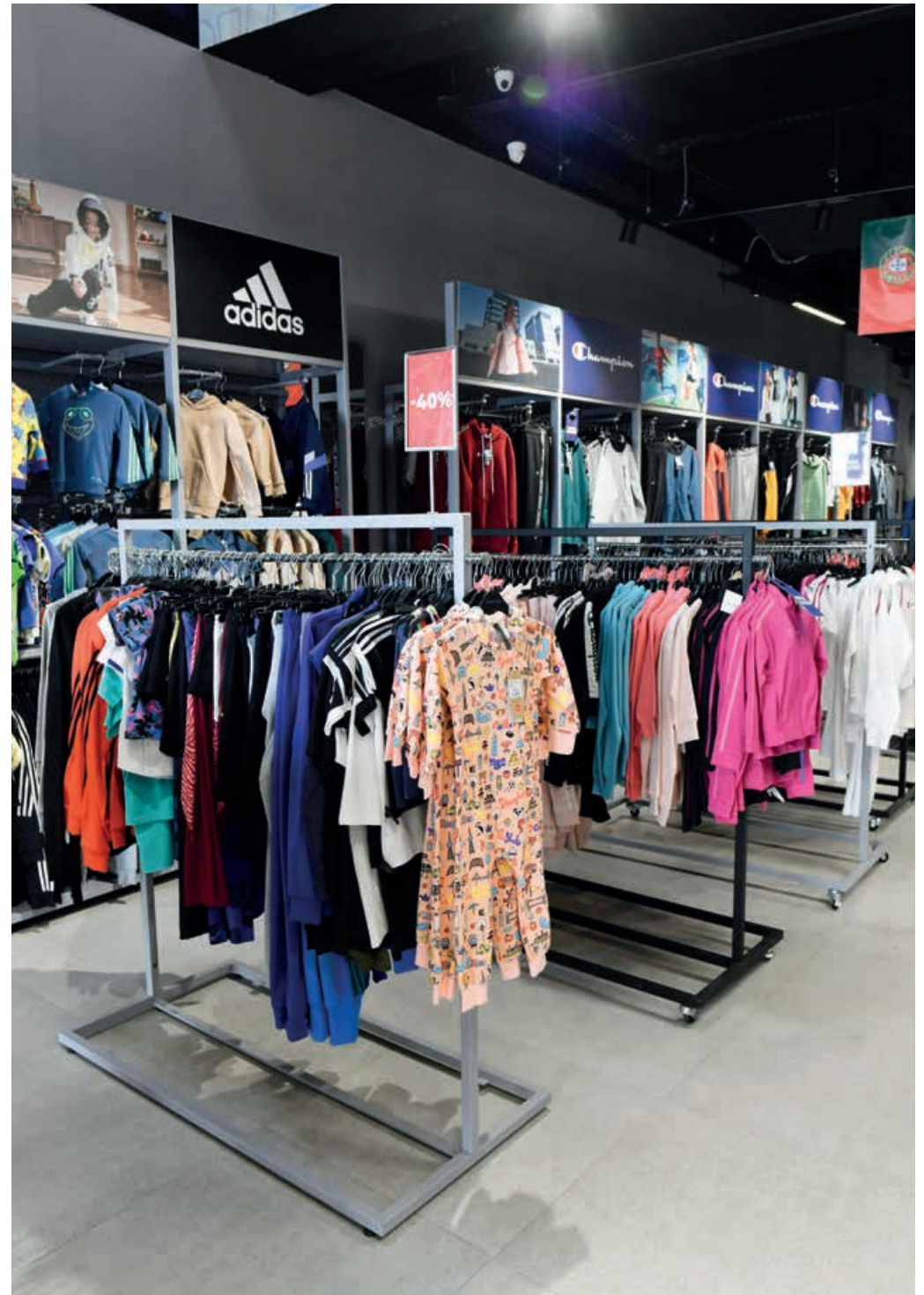



optics & accessories

ÜÇGE's wide range of display units and innovative product lines have the ability to provide the right shopfitting equipment to extract the shine and the specialty of the optics merchandise.

We adapt to the concepts of the sunglass and eyewear brands while using various combined materials to display optical, eyewear, and accessories in stores with the aspects of color, reflections, and diversity of product groups.





home & living

We showcase home decor products in creative concepts that support the store's sleek design. The vision of bringing the warmth of the home into the stores by ÜÇGE offers a pleasing environment high-quality shopping experience.

Combined innovative and organized shelving systems boost the visibility and availability of a great range of home and living products, an excellent feature of ÜÇGE branded display units.





books & stationery

In concept stores that have merchandise of stationery products and books, as well as having the concept of a book cafe, we design and produce shelving systems to provide a better shopping experience.

ÜÇGE also implements specialized projects in this category to reflect the availability of goods and a friendly hospitality approach of the brand that makes customers feel comfortable.





health & beauty

Pharmacies, cosmetics, and drugstores require custom-made sustainable solutions to manage the marketability, accessibility, and restockability of a great range of products. At the same time, we make sure to add value for a healthier shopping phase.







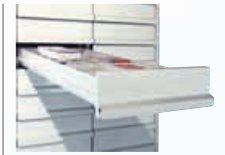

Deep drawers with separators



Perforated upper drawers showing products from below



Drawer steps for providing easy access to upper drawers



electronics

We increase the technological brand recognition for consumer electronics brands. Furthermore, in order to provide ease of access and product availability, ÜÇGE produces and implements functional and organized shelf systems.

With the opportunity for a privileged presentation, we aim to provide the best shopping experiences for the customers.





DIY

DIY hardware stores, where we can find all our home needs, aim to provide most of the requirements in large square-meter spaces.

The DIY stores that are equipped with ÜÇGE branded shopfitting equipment and shelves with large capacities can increase the perception and broaden the customer experience expected from a store to a higher level.







DIY
Low Prices
DÜNYA ÇAPINDA
2.000'DEN
FAZLA MAĞAZA
DIY dünya
10 ülkede

İngilizce & Türkçe
Kampanyalar





shopfitting equipment

ÜÇGE presents the best quality shopfitting equipment to provide ease of shopping and ergonomics and to maintain in-store customer satisfaction.

Systems and equipment that ÜÇGE supplies complement the details for any store design and are always considered the best for the clients.





warehouse

ÜÇGE DRS provides innovative warehouse solutions to global and national brands across logistics, retail, and all industrial branches - specialized in heavy and light-duty warehouse racking systems and smartly designed warehouse projects and storage solutions.





reverse vending systems

"The Technology for Sustainable Future"

Developed vision of a better sustainable future and the requirements for the globally emerging deposit scheme adaptation brought the new initiative into life, the REVEGO brand.

REVEGO solutions is an automated way to collect, sort, and handle the deposit return of used drink containers under the deposit schema regulations. From the design and manufacturing of the hardware and to the flexible & adaptable software are provided by REVEGO

Stand Alone RVMs



RVG-i10G



For PET
and Can



RVG-i20



For PET
and Can



RVG-i30



For Glass, PET
and Can

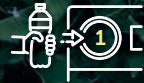
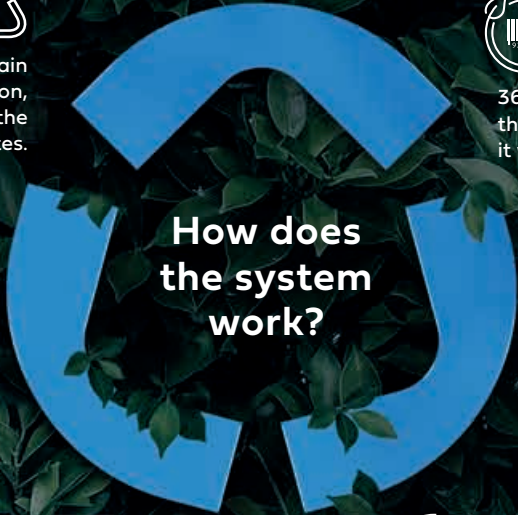

Empty packaging is thrown into the recycling machine.



360° reader recognizes the barcode and matches it with the image and weight.



According to the packaging information, it is separated into PET, can and glass.



Separated packages are crushed and broken for minimum storage volume.

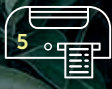

The deposit fee is refunded to the consumer via receipt, mobile wallet or credit card.



Information about all stored packages is instantly collected and reported in the system.



It is connected to the main systems through integration, depending on the regulations of the states.

Mobile Return Station



RVG-i100



For Glass, PET and Can



smart solutions

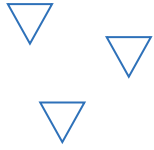

Our new brand **blu.xone**; combines enterprise values and the technological approach systematically within the next-gen solutions under IoT cloud infrastructure.

We are cultivating our vision for the future in order to lead and provide high-technology solutions to the industries we are involved in. With its visionary approach and as innovation has always been a driving value for ÜÇGE, this value is embraced with the synergy of all team members, from the upper management to all levels.

The blu.xone IoT platform consists of groundbreaking technologies such as edge computing, visual recognition, shelf labelling, order picking and image processing at the cloud infrastructure while integrating the technology with the solutions by providing API dashboards and customized web services that are in flexible integration with the currently owned systems.

blu.xone
Smart Solutions

electronic shelf label system

ÜÇGE's ESL system provide the opportunity for your store to share the most up-to-date and detailed information by price tags, minimizing the labor and informing your customers with the correct details.

In addition, the system aims to ensure operational management continuity while transferring the information change process to the digital environment. This way, paper waste is prevented, and many time-consuming problems are eliminated.



Data Automation

Both manual and automatic data transfer



Authorization Module

User creation and authorization



Advanced Report Formats

Reporting and log archive on a product and label basis



Promotion Planning

Integrated promotional price calendar scoring module



Automatic Backup

Backup · restore from backup disaster recovery solution



Remote Maintenance

Ticket system for service



How it works?

alternative 1

Cloud Configuration

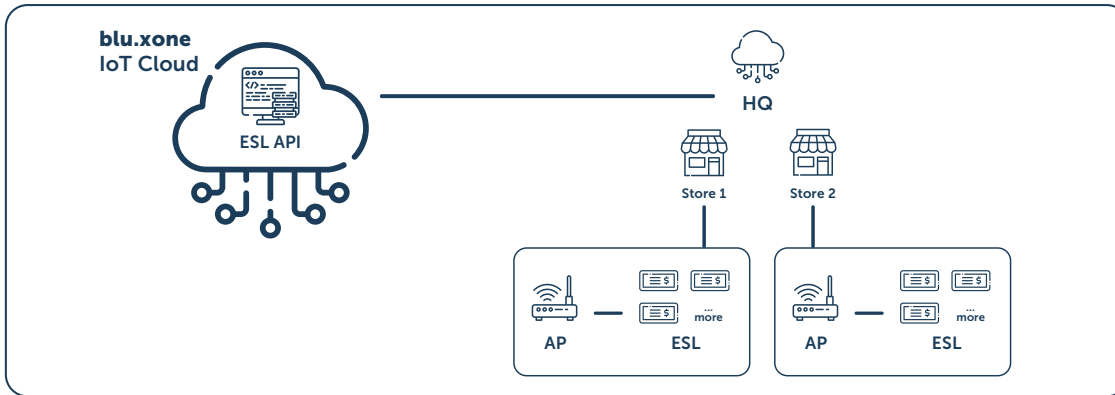

alternative 2

On-Premise Configuration

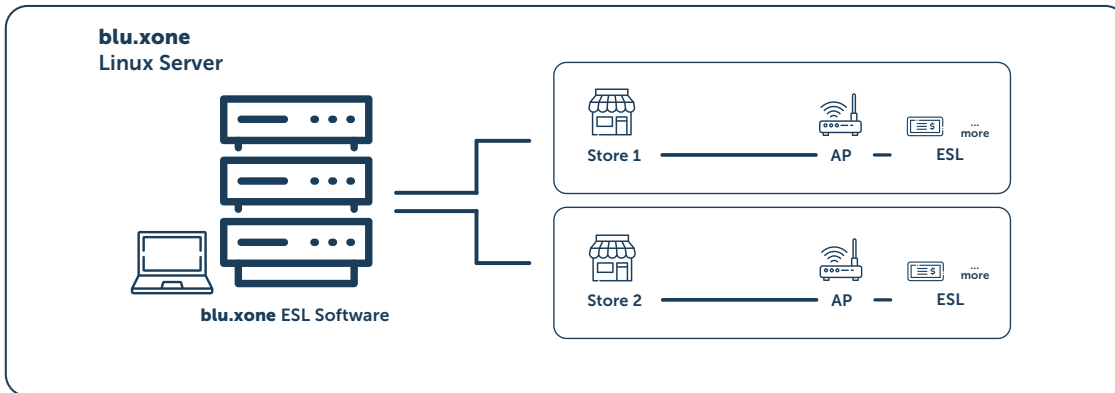

blu.xone NFC Configuration

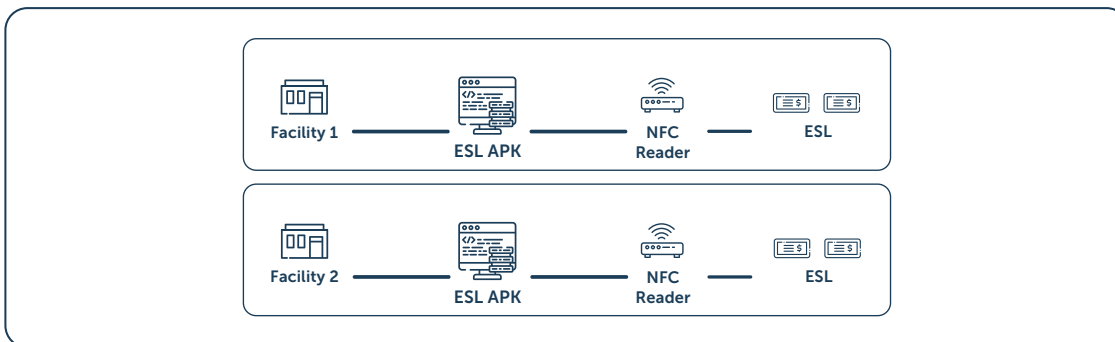

order management wizard

Designed to improve order collection performance, Order Management Wizard retouches the order collection process while seamlessly integrating into the current planogram and layout plans.

Built onto ÜÇGE's ergonomic order-picking trolley, the software significantly reduces labor costs and the margin of error for each e-commerce order. In addition, the software offers flexible integration to the external e-commerce dashboards and internal stock-keeping databases while providing the analytical data for brands to develop the picking & restocking processes.

The picking-aid navigation screen supports the layouts in panoramic 2D or AR based 3D per choice.



**AR
Navigation**



**Order
Picking
Assist**

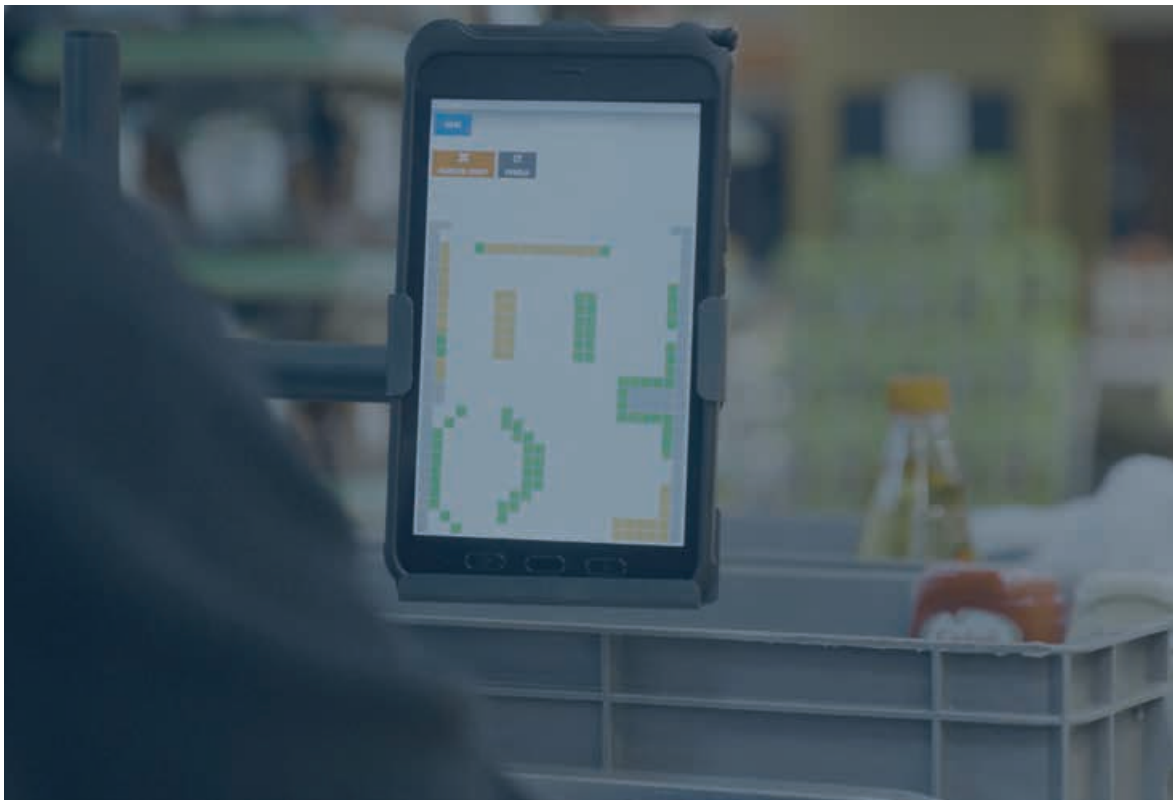
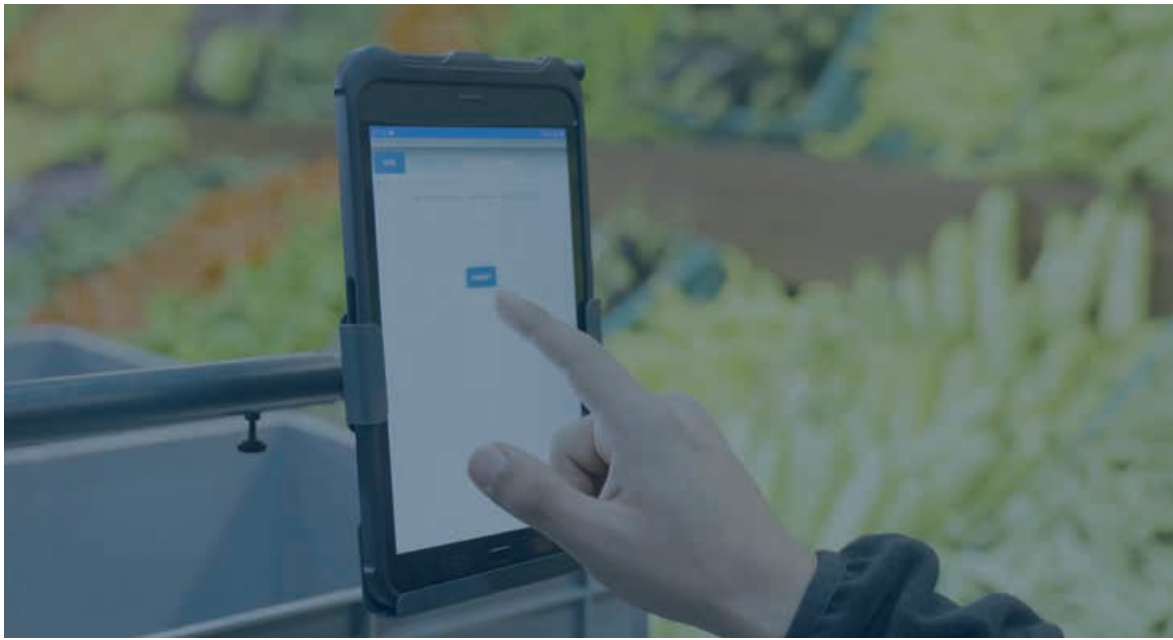

density map software

Understanding the customer journey in retail has been a great challenge for brands where the interest depends on the customer flow, dwelling times between aisles, and product visibility compared with shopper engagement.

ÜÇGE provides a must-have analytical system for any retail concept that converts the statistical movement data into significant findings to improve merchandising activities and reshape the store layout.

The software is built on image processing technology, computing the data in seconds taken from the visuals by in-store cameras and turning them into the report formats for a crucial understanding of the store layout's heatmap while conforming to the data privacy regulations via specialized human recognition format.

CROWD COUNTING: 2





crowd counting software

Check-out counters are the last touch point with the customers in the store. Therefore, providing a seamless checkout process is an excellent brand feature that significantly increases consumer satisfaction.

Taking action via real-time data is indispensable in the retail industry. Considering in-store operations efficient for everybody, blu.xone check-out area crowd-counting software provides real-time counting and image processing in the specialized area.

The smart tracking software informs the store executives of any inconvenience with the queue time. Therefore providing the opportunity to take action within minutes, to solve the stoppages, elevate customer satisfaction and optimize employee work schedules, conforming to the data privacy regulations via specialized human recognition format.



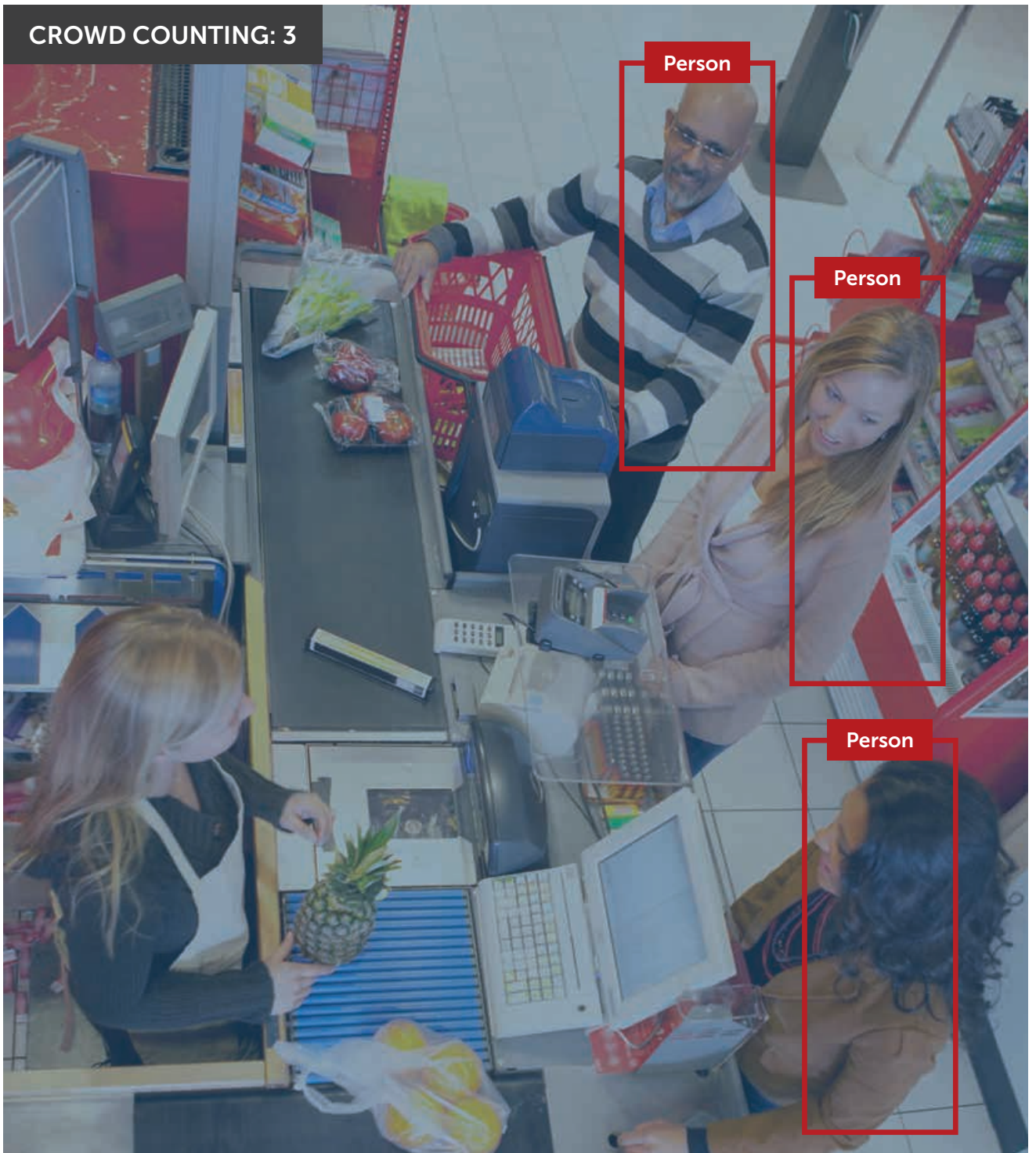

sensors

Managing the proper preservation of goods without breaking the cold chain, storing them fresh, and offering the merchandise within accurate temperature limits is the traditional expectation from the industry.

The capability of the all-in-one sensors provide additional metrics; air quality, particle amount, humidity, sound level and much more to analyze and optimize.



Dynamic consumer and employee engagements along the store's refrigerated units and the merchandise exposure to different temperatures may lead to unhygienic conditions.

Implemented sensors monitor the temperature data instantly in the cooler units and cold air rooms and feed the blu.xone traceability software dashboard. Therefore, configured with the threshold values - the activated alarm mechanism warns the executives to take action within minutes.

The system not only provides safe merchandise shopping but also helps energy management protocol to stay under control. In contrast, the system prevents losses and decreases the food waste margin caused by unconventional temperature conditions.





family shopping mobile app

The Family Mobile Application app is a shopping experience solution offered to consumers. The app can work integrated with different e-commerce platforms. At the same time, the lists can be shared, and multiple users can access and configure the lists in the application.

As the software was developed in the sense of creating shopping lists should also be entertaining, the solution provides better engagement on product purchases and detailed product orientations.

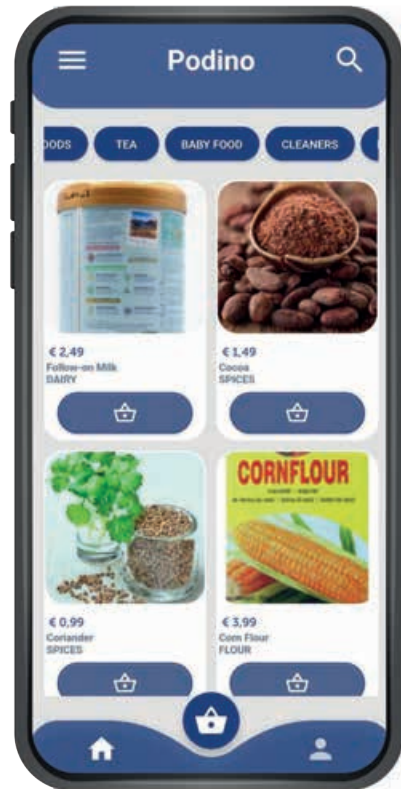

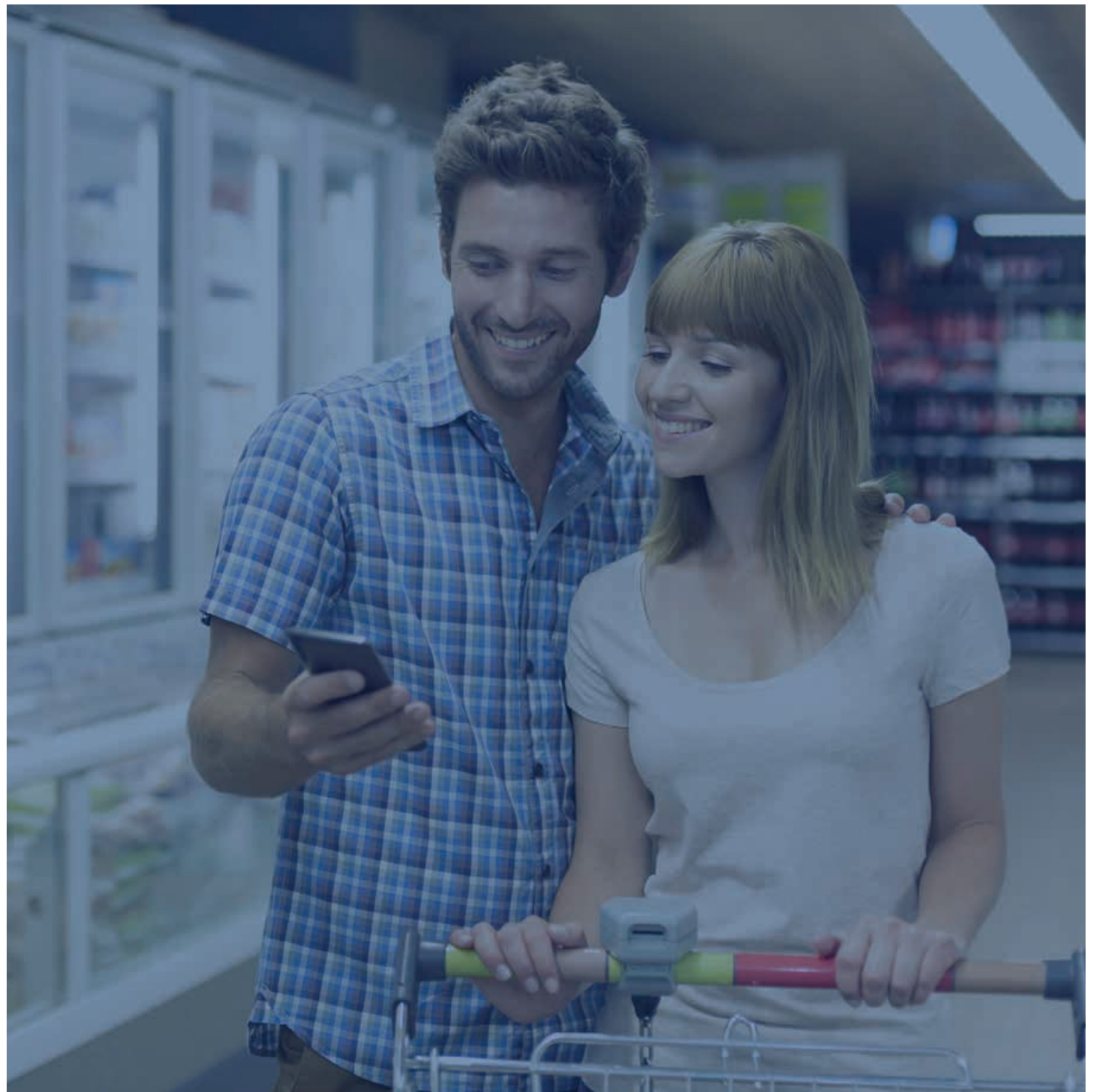

ODIS automated vertical storage system

ÜÇGE combined technology with practical use to provide future-proven innovative solutions for all spaces in any industry. ODIS system offers both conceptual retail industry solutions separately; timeless pick-up of e-commerce orders and an automated dark store concept.

The system is cost-effective and fully automated with the integration of logistics databases of e-commerce platforms.

24/7 Pick-up with ODIS

ODIS was developed to benefit from the unused height spaces, stacking the goods vertically with the aid of the innovative shuttle robot moving in 2-axis, simplifying the automated storage and retrieval system method - commonly used in sophisticated warehouses.

As online grocery shopping and e-commerce industries are gaining a significant volume today, ODIS' built-in trays are stacked into the vertical storage system to provide fresh and safe storage of E-commerce orders. Combining the edge points - the consumer intent to pick up and the logistics operations, the goods can be picked up by the consumer anytime, as the system is designed to function for 7/24.



24/7 Automated Retail Service

ODIS is configured into a dark store mechanism in another conceptual application model. As the merchandising activities and restocking are automatic, the trays of the vertical stacking system function as shelves. The built-in sensors automatically check product availability, and the smart robot operates the restocking.

The system perfectly combines blu.xone technologies to provide seamless and automated error-free next-generation shopping preferences.

Maximize The Storage Space Efficiency

With its functional design, ODIS provides maximum storage efficiency in minimum space by eliminating the need of horizontal storage space and intralogistics supply problems. The system provides energy, space and time advantages when implemented functionally as a buffer storage.

By minimizing the storage and supply costs, ODIS increases the operational efficiency of businesses with a technological and systematic storage management approach.





• *The patent of the products in this catalog and the publication right of the information belong to ÜÇGE.
It cannot be copied, reproduced or published without permission.*



ÜÇGE Mağaza Ekipmanları AŞ | Shopfitting & Design

Işıktepe OSB Kahverengi Cad. No:16 16215 Nilüfer, Bursa TÜRKİYE T: +90 224 280 00 00
| ucge.com | bluxone.ucge.com | sales@ucge.com |

ucgetr / ucgeint | ucgetr | ucge | ucgetv